

Axial rolling system RS10

Type stationary

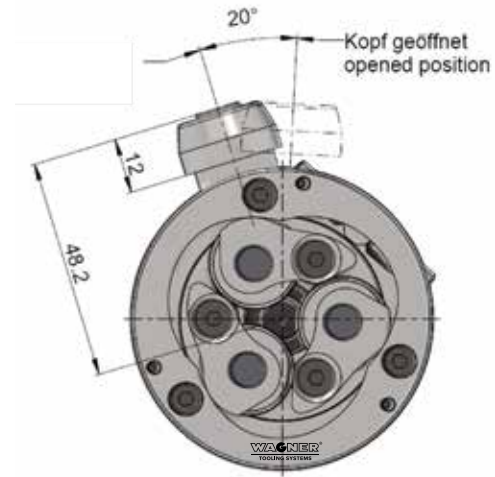
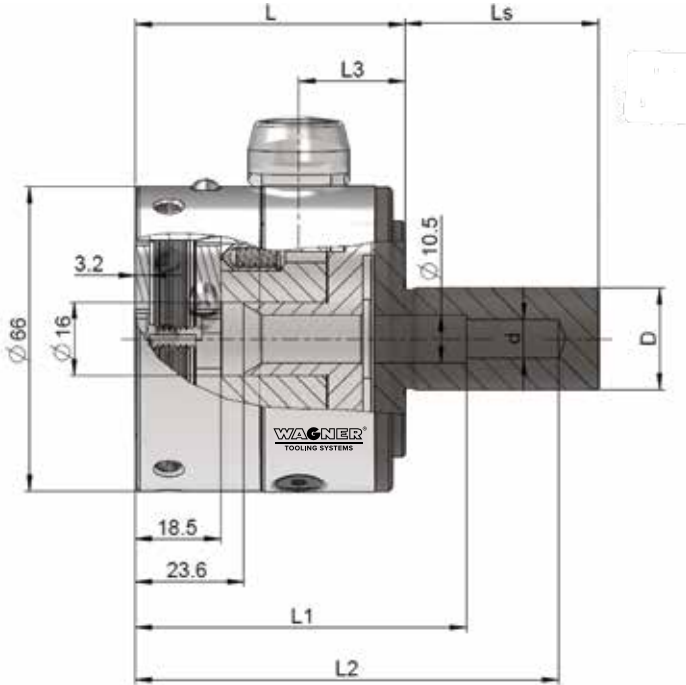

Axial rolling system RS10

Weight 1.2 kg

	mm	inch
Working range \varnothing	2.5–10	0.1–0.394
Pitch max.	1.5	16 t.p.i.

Shank- \varnothing D mm (inch)	d mm	L mm	L _s mm	L ₁ mm	L ₂ mm	L ₃ mm
10	5	58.5	42	51	∞	23
12	5	58.5	42	51	∞	23
16	–	58.5	42	∞	–	23
19.05 (3/4")	–	58.5	42	∞	–	23
20	–	58.5	42	∞	–	23
22	–	58.5	42	∞	–	23
22	–	58.5	100	∞	–	23
25	–	58.5	48	∞	–	23
25.4 (1")	–	58.5	48	∞	–	23
28.5	–	58.5	51	∞	–	23
40	–	56.3	60	98	–	20
VDI16	8.5	63.3	32	87	–	27
VDI20	8.5	68.3	40	72	101	33
VDI25	–	74.3	48	114	–	38
VDI30	–	74.3	55	120	–	38