

Axial rolling system RS27/56

Type stationary

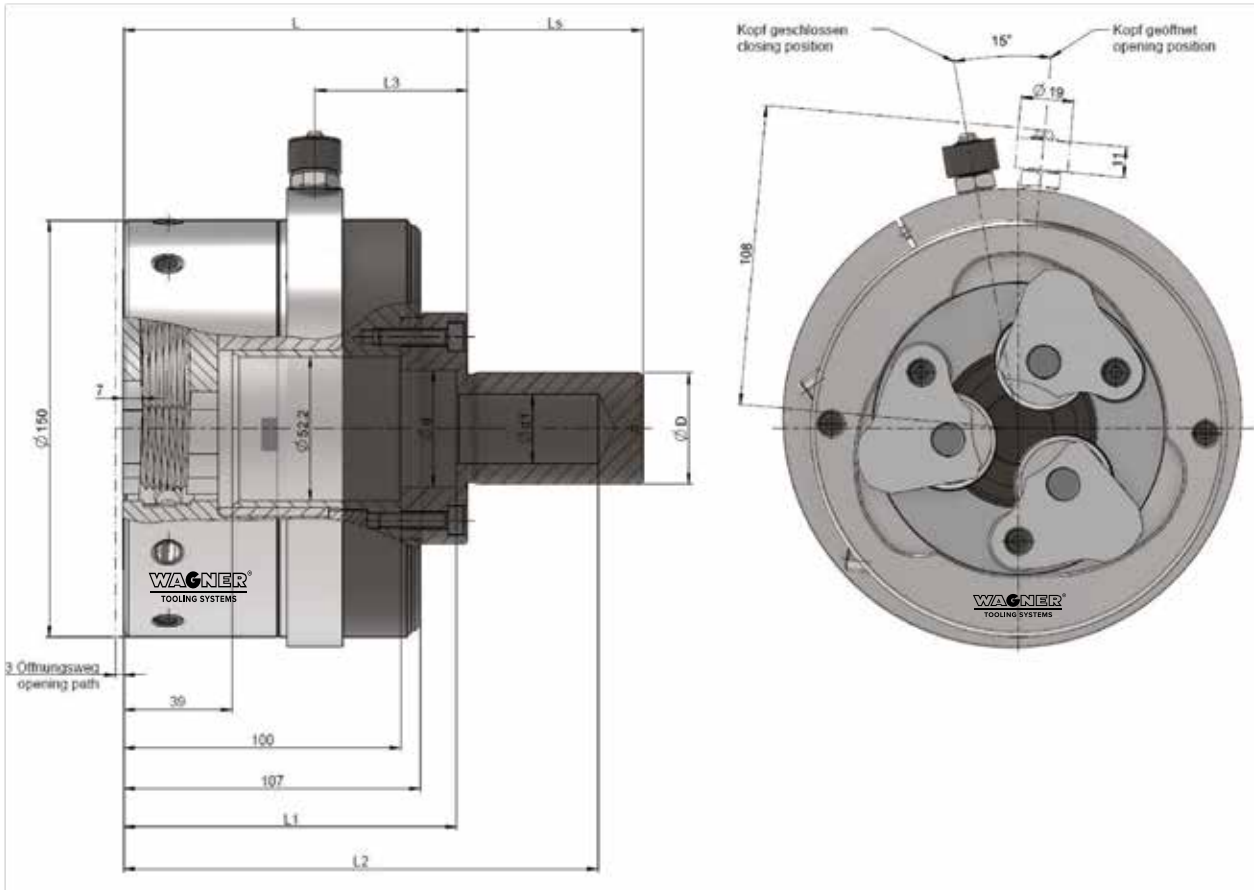

Axial rolling system RS27/56

Weight 11 kg

	mm	inch
Working range \varnothing	5–56	0.197–2.087
Pitch max.	3	8t.p.i.

Shank- \varnothing D mm (inch)	d mm	d1	L mm	L ₅ mm	L ₁ mm	L ₂ mm	L ₃ mm
25	18.2	–	175.3	65	∞	–	42.5
25.4 (1")	18.2	–	175.3	65	∞	–	42.5
30	23.5	M25 × 1.5	175.3	80	∞	–	42.5
31.75 (1 1/4")	23.5	M25 × 1.5	175.3	80	∞	–	42.5
32	23.5	M25 × 1.5	175.3	80	∞	–	42.5
36	23.5	G1/4"	175.3	100	190	–	42.5
38.1 (1 1/2")	23.5	–	175.3	88	∞	–	42.5
40	27.2	M28 × 1.5	175.3	80	170	–	42.5
50	38.5	–	175.3	120	∞	–	42.5
50.8 (2")	38.5	–	175.3	65	∞	–	42.5
60	42	–	175.3	120	∞	–	42.5
VDI30	30	16.2	124	55	120	169	58.5
VDI40	42	25	124	63	120	171	58.5
VDI50	42	27.2	124	78	120	186	58.5