

Axial rolling system RS42 and RS42/75

Type stationary

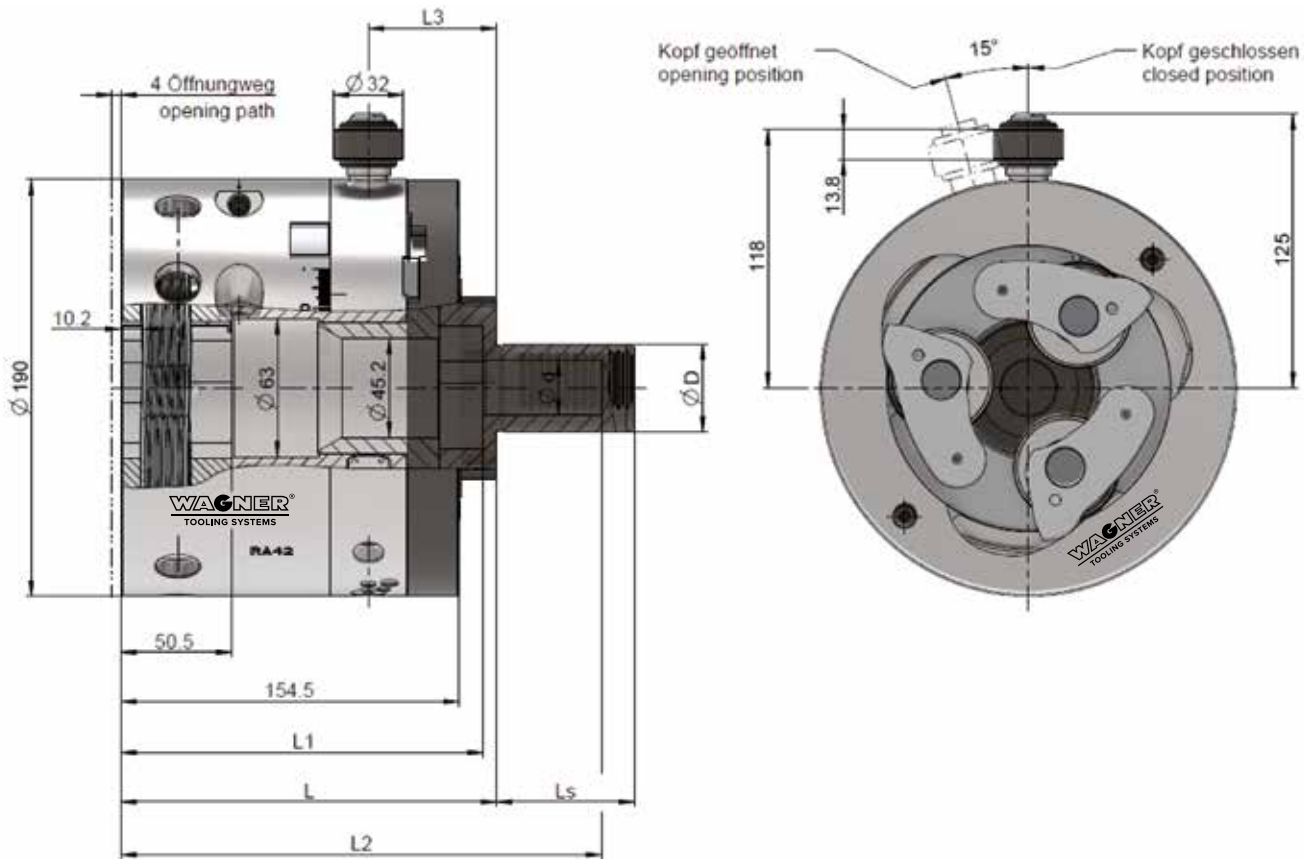

Axial rolling system RS42 and RS42/75

Weight 28 kg

	mm	inch
Working range \varnothing	8–75	0.315–1.654
Pitch max.	4.5	6 t.p.i.

Shank- \varnothing D mm	d mm	L mm	L _s mm	L ₁ mm	L ₂ mm	L ₃ mm
32	15	155.5	75	146.5	∞	42.5
40	30	155.5	120	146.5	∞	42.5
50	39.5	155.5	120	146.5	259.5	42.5
50	33	175.5	120	146.5	∞	62.5
50	39.5	155.5	120	146.5	∞	42.5
60	48.4	155.5	120	∞	–	42.5
VDI30	16.2	171.5	55	165.5	219.5	58.5
VDI40	25	171.5	63	165.5	219.5	58.5
VDI50	32	171.5	78	165.5	232.5	58.5