

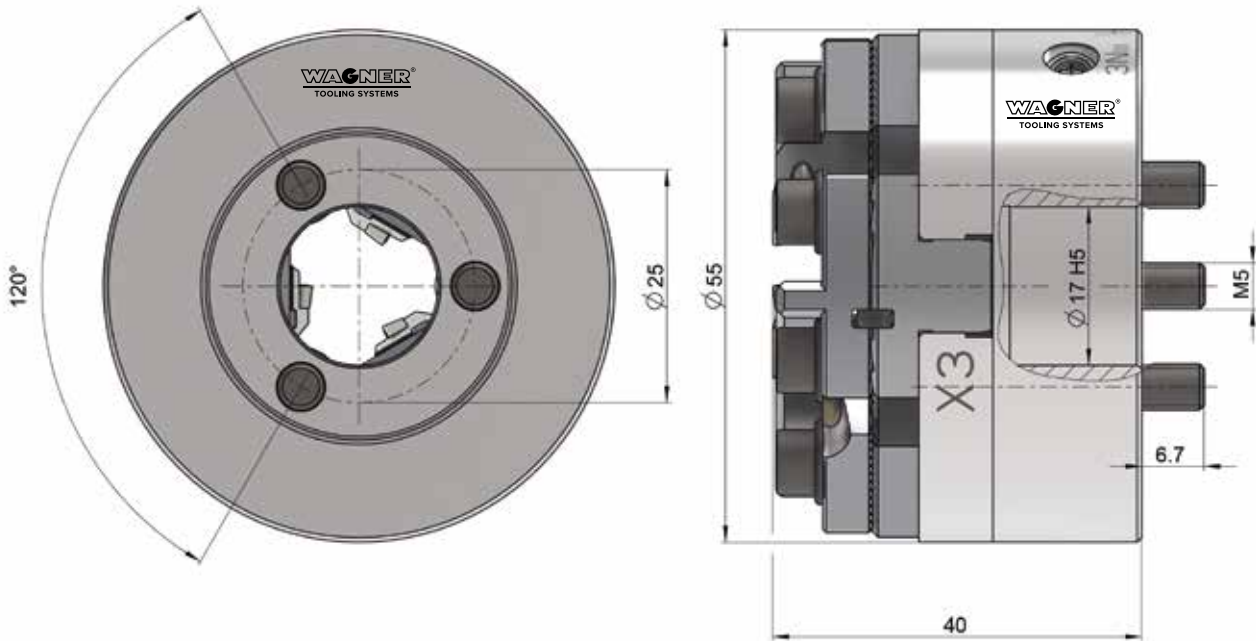

Mehrschneiden-Drehsystem DSD12



Wendeplattenhalter	Wendeplatten	Schneidenlage	Arbeitsbereich
Z5.0 SCMT90	ISO SCMT0602	90°	1–12 mm

Abbildung: Schaftmaße siehe Tabelle

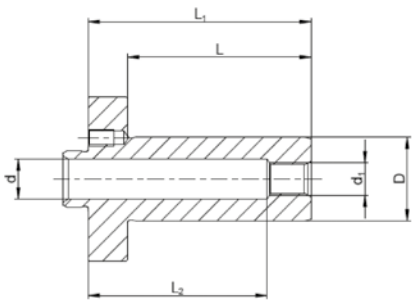

Schaft-Ø D mm (Zoll)	d mm	d ₁	L mm	L ₁ mm	L ₂ mm
12	5	M6	34	46	38
16	7	G1/8"	48	60	48
19,05 (3/4")	12,2	G1/8"	46	58	47,5
20	12,2	G1/8"	46	58	47,5
22	12,2	G1/8"	46	58	47,5
25,4 (1")	12,2	G1/8"	56	68	54,5
Sonderschäfte auf Anfrage					