

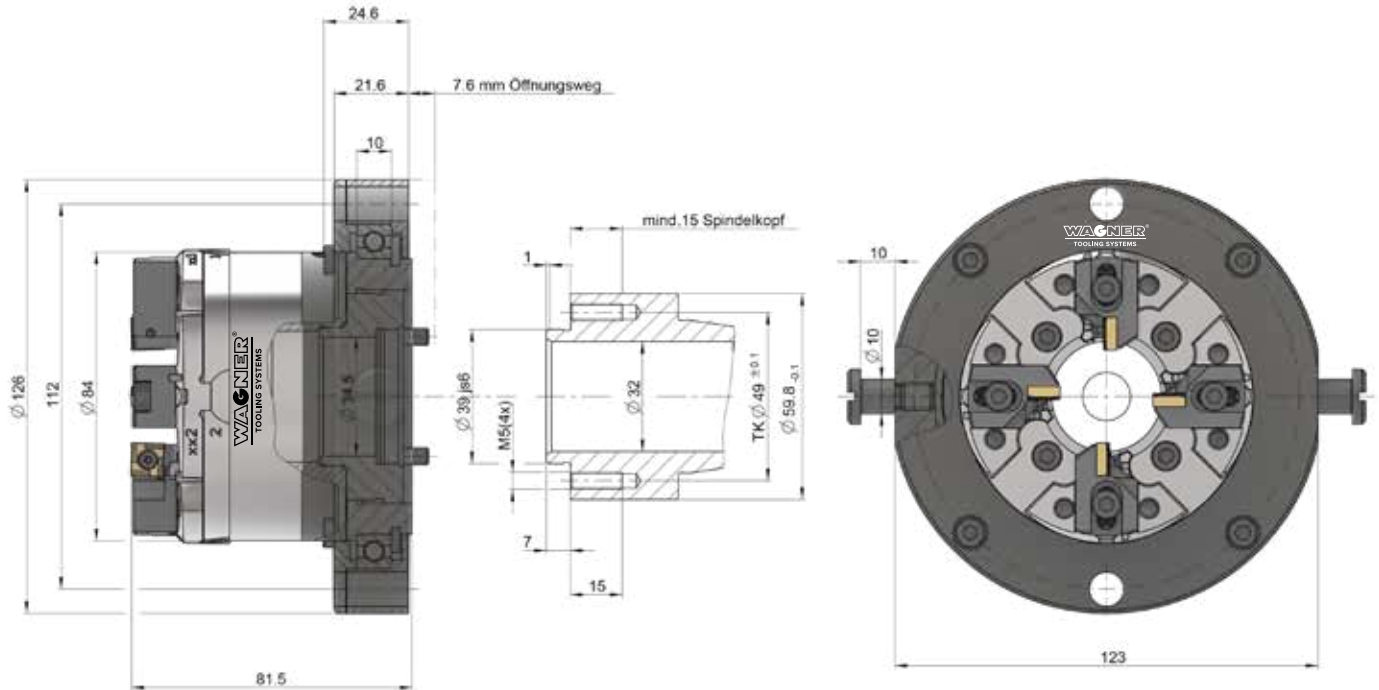

Mehrschneiden-Drehsystem MSD300



Wendeplattenhalter	Wendeplatten	Schneidenlage	Arbeitsbereich
W01 B5.0	Wagner W01	89°	16–30 mm
Z5.1 SCMT89	ISO SCMT09T3	89°	16–30 mm
Z5.1 CCGT90	ISO CCGT09T3 ISO CCMT09T3	90°	16–30 mm
Z5.1 SCMT45	ISO SCMT09T3	45°	16–35 mm (Fasen)

Zubehör:

Schäfte und Flansche auf Anfrage

