

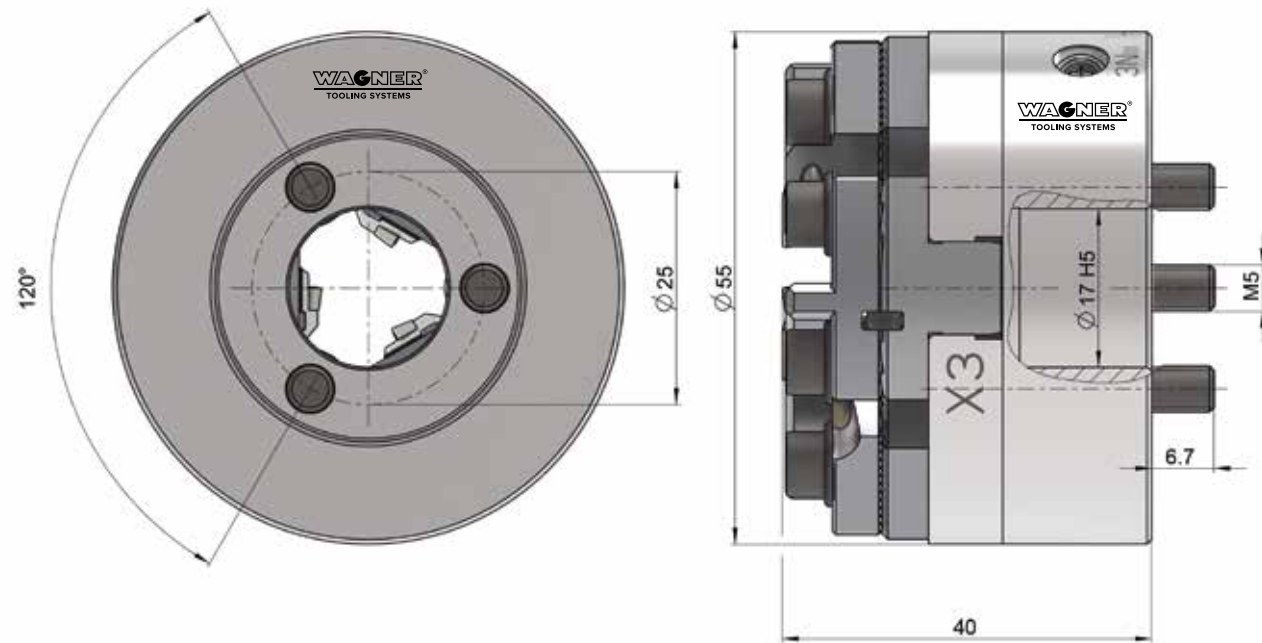

Multi-cutter Turning System DSD12



Insert holders	Cutting inserts	Cutting edge position	Working range
Z5.0 SCMT90	ISO SCMT0602	90°	1–12 mm

Figure: Shank dimensions see table

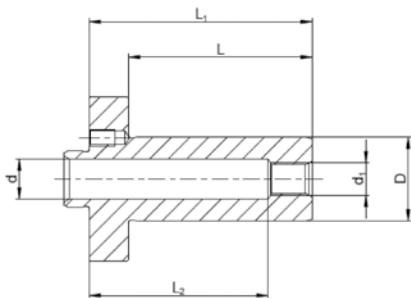

Shank-Ø D mm (inch)	d mm	d ₁	L mm	L ₁ mm	L ₂ mm
12	5	M6	34	46	38
16	7	G1/8"	48	60	48
19.05 (3/4")	12.2	G1/8"	46	58	47.5
20	12.2	G1/8"	46	58	47.5
22	12.2	G1/8"	46	58	47.5
25.4 (1")	12.2	G1/8"	56	68	54.5
Special shanks on request					