

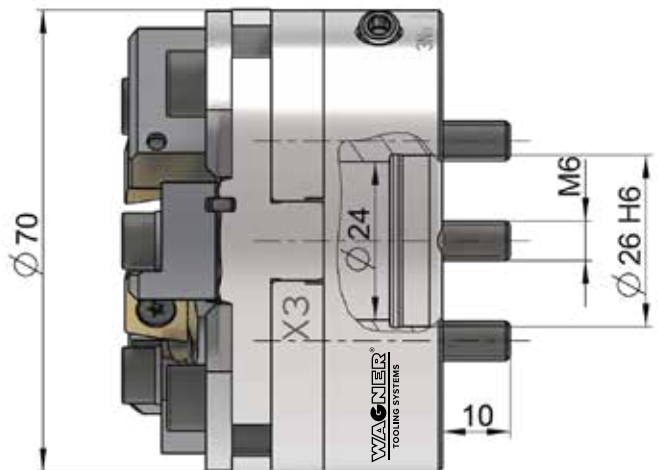

Multi-cutter Turning System DSD16

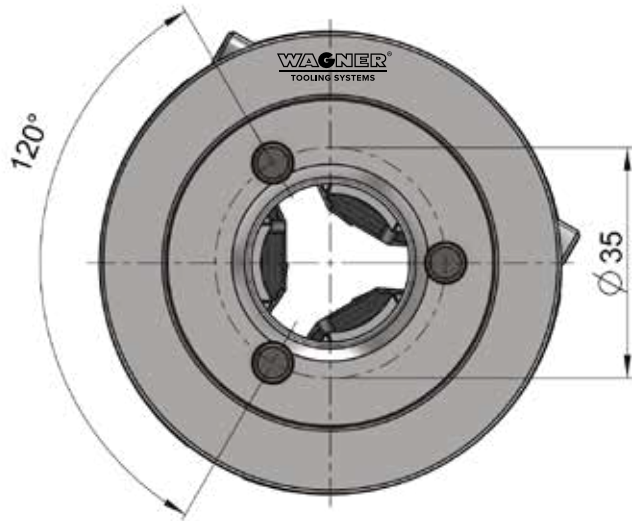

Insert holders	Cutting inserts	Cutting edge position	Working range
W01 B5.0	Wagner W01	89°	1–16 mm
Z5.0 SCMT90	ISO SCMT09T3	89°	1–16 mm
Z5.0 CCGT90	ISO CCMT09T3	90°	1–16 mm
Z5.0 SCMT45	ISO SCMT09T3	45°	2–25 mm (Chamfering)
Z5.0 TCMT16-30	ISO TCMT16T3	30°	2–30 mm (Chamfering)

Figure: Shank dimensions see table

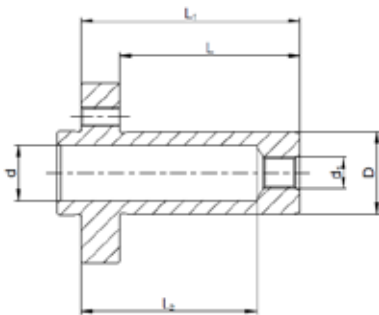

Shank-Ø D mm (inch)	d mm	d ₁	L mm	L ₁ mm	L ₂ mm
16	10,2	R1/8"	46	58	47,5
19.05 (3/4")	12,2	R1/8"	46	58	47,5
20	12,2	R1/8"	46	58	47,5
25	17	R3/8"	50	62	46
25.4 (1")	17	R1/8"	56	68	54,5
35	10	R1/2"	80	92	62
40	16.2	M6	120	132	57,5
VDI20	16.5	–	40	55	14,5
VDI25	16.2	–	48	65	22,5
VDI30	16.2	–	55	72	57,5
Special shanks on request					