

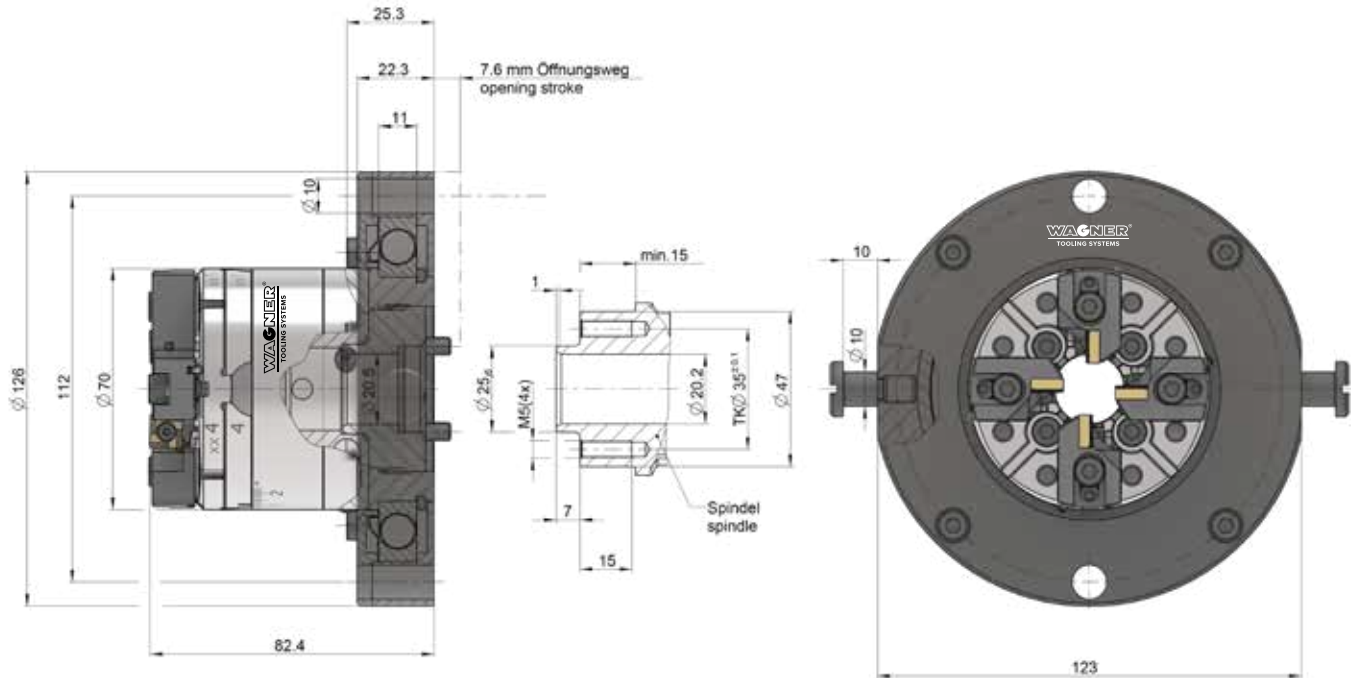

Multi-cutter Turning System MSD20R



Insert holders	Cutting inserts	Cutting edge position	Working range
W01 B5	Wagner W01	89°	1–16 mm
W02 B5	Wagner W02	89°	16–20 mm
Z5.1 SCMT89	ISO SCMT09T3	89°	1–16 mm
Z5.1 CCGT90	ISO CCGT09T3	90°	1–16 mm

Accessories:

Special shanks on request

