

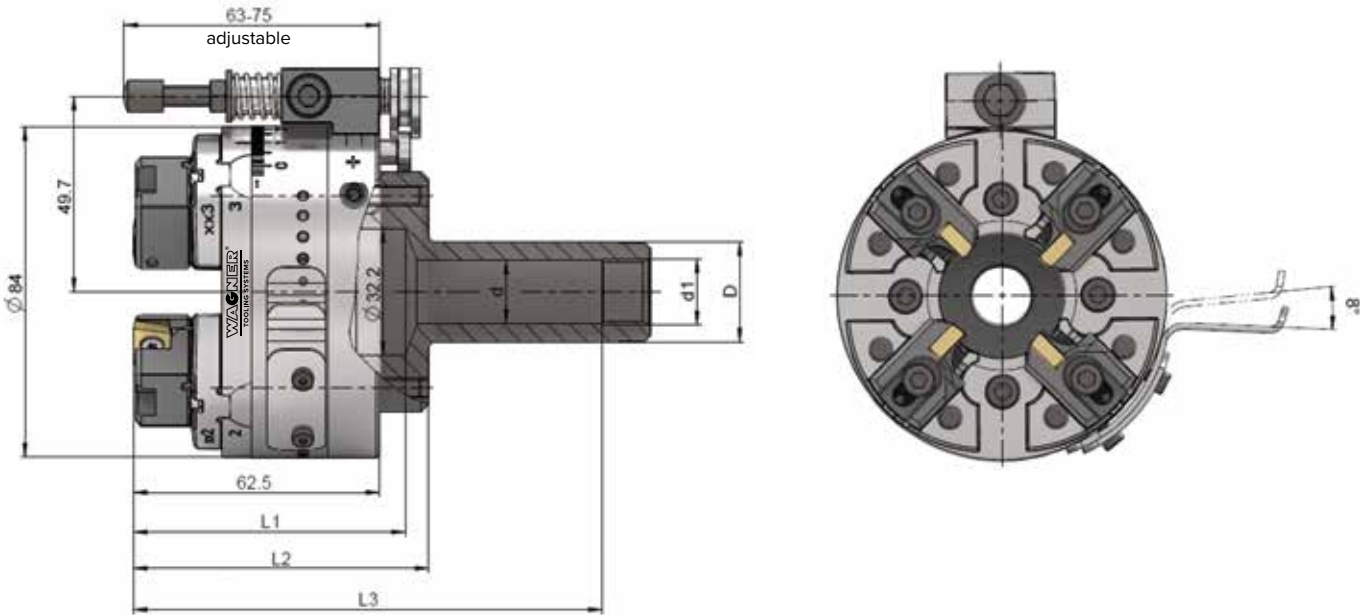

Multi-cutter Turning System MSD30



Insert holders	Cutting inserts	Cutting edge position	Working range
W01 B5.0	Wagner W01	89°	16–30 mm
Z5.1 SCMT89	ISO SCMT09T3	89°	16–30 mm
Z5.1 CCGT90	ISO CCGT09T3 ISO CCMT09T3	90°	16–30 mm
Z5.1 SCMT45	ISO SCMT09T3	45°	16–35 mm (Chamfering)

Shank-Ø D mm (inch)	d mm	d ₁	L mm	L ₁ mm	L ₂ mm	L ₃ mm
25	16	R3/8"	56	68	74	118
25.4 (1")	16	R1/8"	56	68	74	118
30	21	R1/2"	63	68	74	125
40	32	R1/2"	120	–	74	182
50	32	R1/2"	120	–	74	182
VDI30	16,2	–	55	–	88	82