

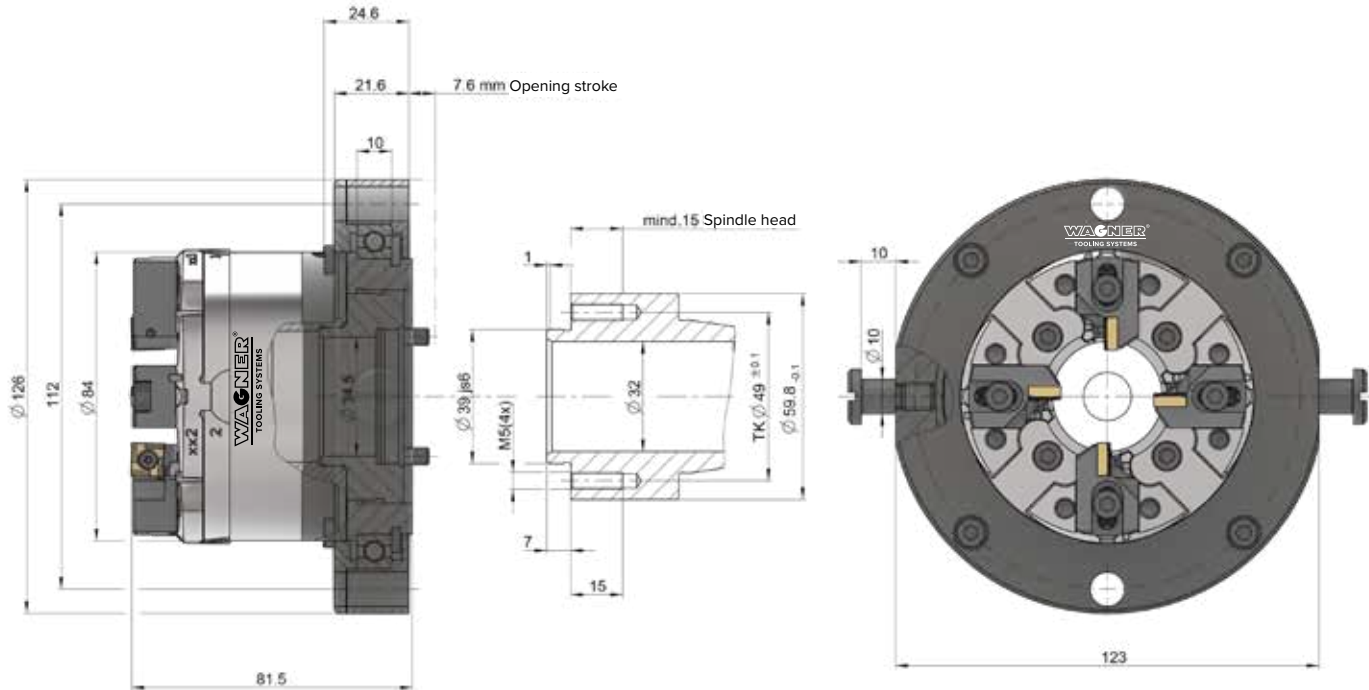

Multi-cutter Turning System MSD30R



Insert holders	Cutting inserts	Cutting edge position	Working range
W01 B5.0	Wagner W01	89°	16–30 mm
Z5.1 SCMT89	ISO SCMT09T3	89°	16–30 mm
Z5.1 CCGT90	ISO CCGT09T3 ISO CCMT09T3	90°	16–30 mm
Z5.1 SCMT45	ISO SCMT09T3	45°	16–35 mm (Chamfering)

Accessories:

Special shanks on request

