

## Gewinde-Schneidsystem W GK-WHK

Bauart Heavy Duty umlaufend

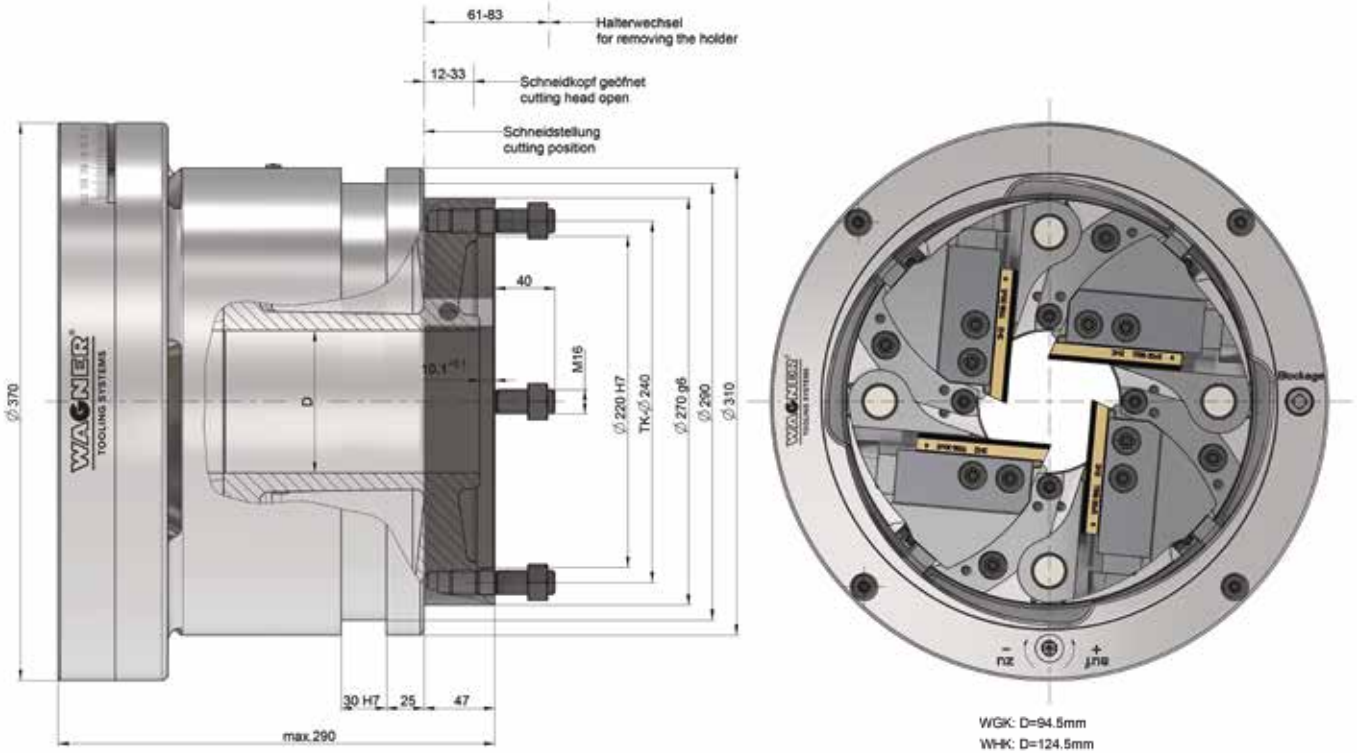

### Gewinde-Schneidsystem Heavy Duty W GK-WHK

Arbeitsbereich $\varnothing$		Gewicht		
Metrische Regelgewinde Metrische Feingewinde	Whitworth- und UN- Gewinde	Whitworth-Rohrge- winde und NPT- Gewinde	Trapez- und Rundgewinde $\varnothing$	
W GK	M12–M76	1/2–3 1/2"	G1/2–3" R1/2–3" 1/2-14–3-8NPT	12–62 mm 0,39–1,73"
W HK	M12–M76 M18 $\times$ 1.5–M88 $\times$ 3	1/2–3 1/2"	G1/2–4" R1/2–3" 1/2-14–4-8NPT	12–62 mm 0,47–2,44"
Strehlerhalter	siehe Haltertabellen			

### Zubehör:

Einstellvorrichtung mit Messuhr



### Zubehör:

Steuerung W GK-WHK

