

Thread cutting system WDK-WEK

Heavy duty rotating design

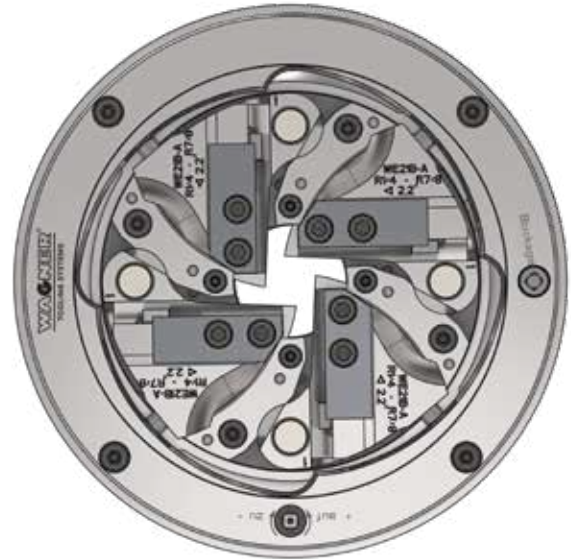
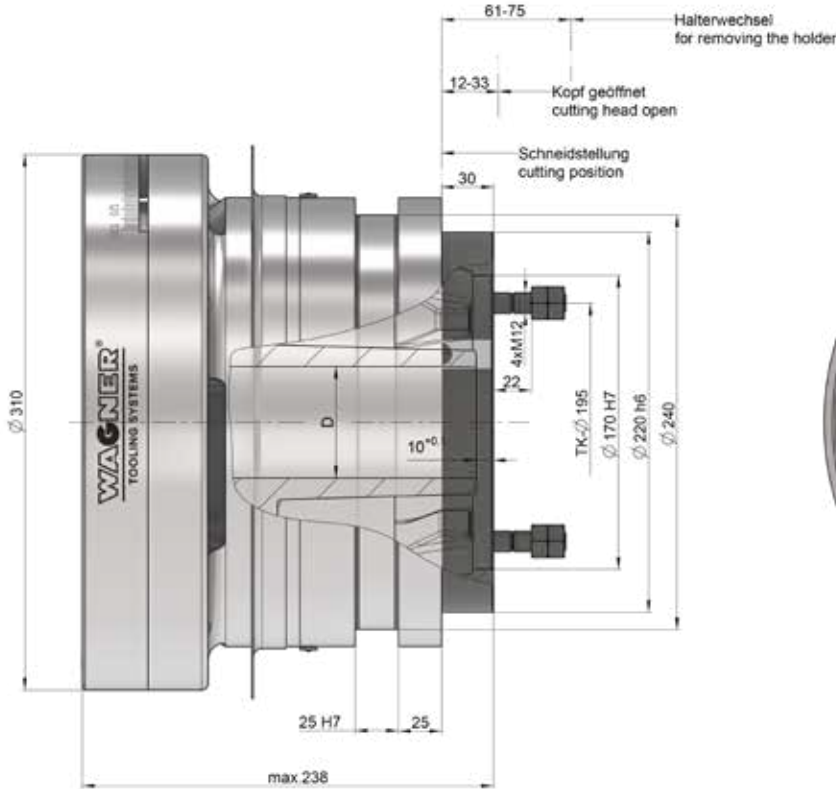

WDK: D = 64,5mm
WEK: D = 94,5mm

Thread cutting system Heavy Duty WDK-WEK

Working range \varnothing		Weight			
	Metric standard threads Metric fine threads	Whitworth and UN threads	Whitworth pipe threads and NPT threads	Trapezoidal and round threads \varnothing	
WDK	M8–M52	3/8–2"	G1/4–2" R1/4–2" 1/4-18–2-11.5NPT	10–44 mm 0.39–1.73"	50 kg
WEK	M8–M52 M16 × 1.5–M88 × 3	3/8–3"	G1/4–3" R1/4–3" K1/16 1/4-18–3-8NPT	10–44 mm 0.39–1.73"	50 kg

Chaser holders see table for holders

Accessories:

Setting device with dial gauge



Accessories:

Control ring WDK-WEK

