

## Thread cutting system WGK-WHK

Heavy duty rotating design

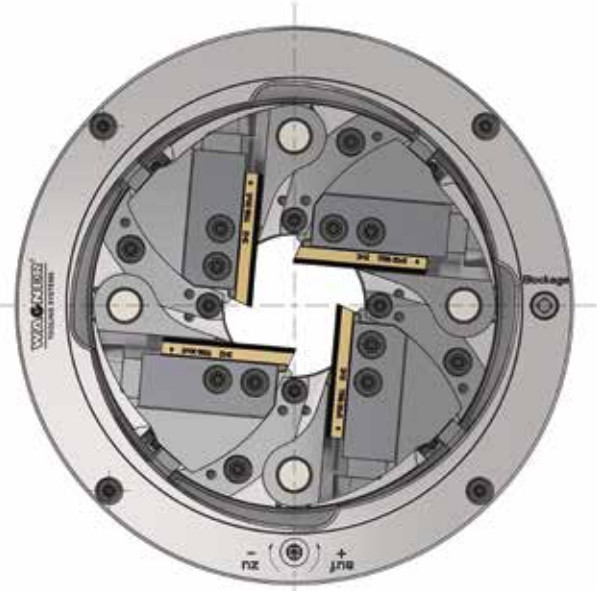
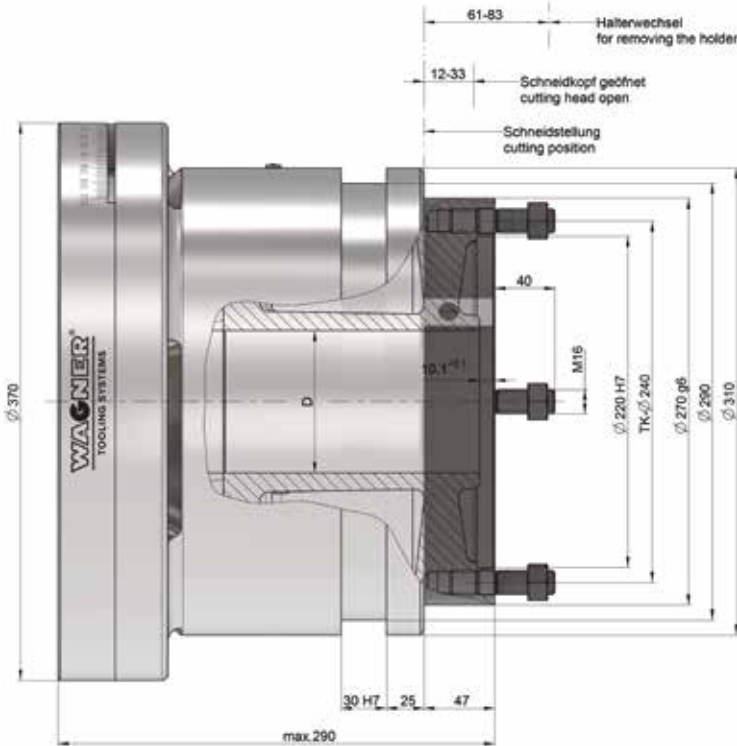

WGK: D=94.5mm  
WHK: D=124.5mm

### Thread cutting system Heavy Duty WGK-WHK

Working range $\varnothing$					Weight
	Metric standard threads Metric fine threads	Whitworth and UN threads	Whitworth pipe threads and NPT threads	Trapezoidal and round threads $\varnothing$	
WGK	M12-M76	1/2-3 1/2"	G1/2-3" R1/2-3" 1/2-14-3-8NPT	12-62 mm 0,39-1,73"	90 kg
WHK	M12-M76 M18 x 1.5-M88 x 3	1/2-3 1/2"	G1/2-4" R1/2-3" 1/2-14-4-8NPT	12-62 mm 0,47-2,44"	90 kg

Chaser holders see table for holders

### Accessories:

Setting device with dial gauge



### Accessories:

Control ring WGK-WHK

