

Thread cutting system WJK-WKK

Heavy duty rotating design

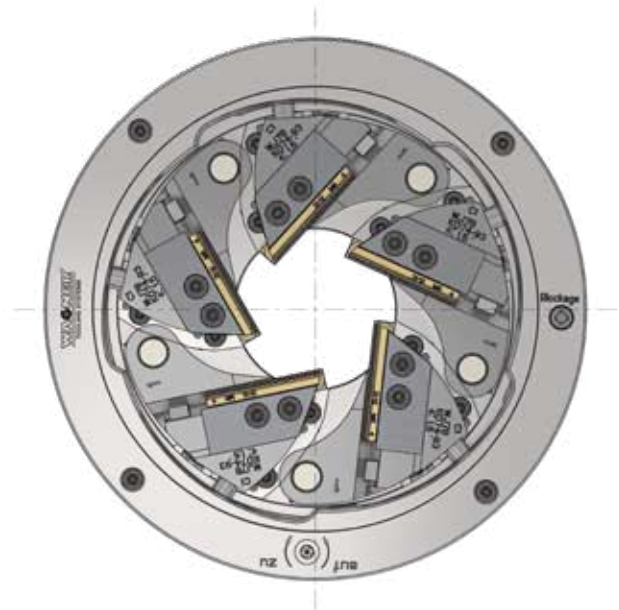
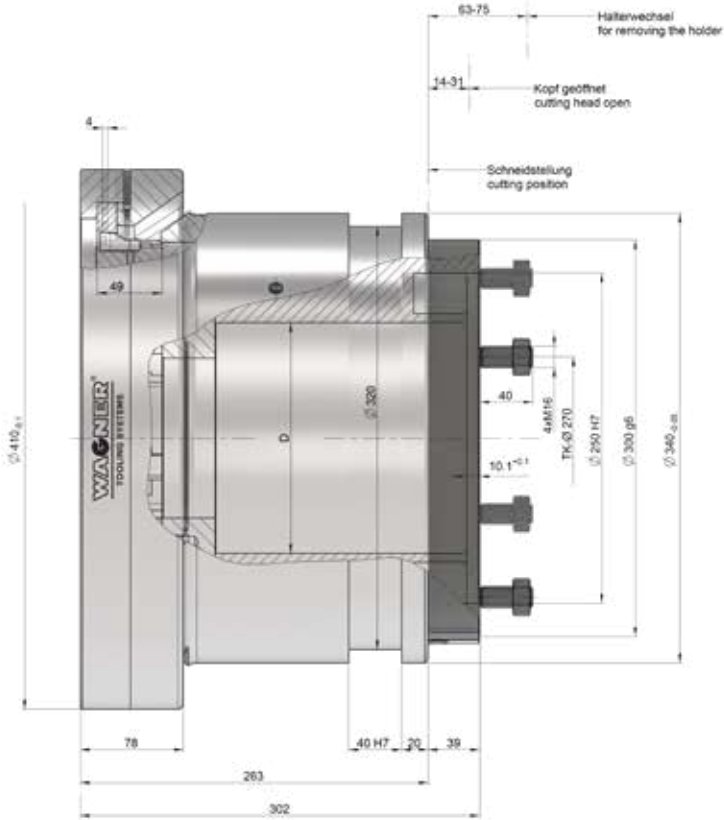

WJK: D = 119.5
WKK: D = 174.5

Thread cutting system Heavy Duty WJK-WKK

Working range Ø

Weight

	Metric standard threads Metric fine threads	Whitworth and UN threads	Whitworth pipe threads and NPT threads	Trapezoidal and round threads Ø	
WJK	M24–M100	1–4"	G1–4" R1–4" 1-11½–4-8NPT	24–90 mm 0.94–3.5"	140 kg
WKK	M24–M100 M30 × 1.5–M120 × 2	1–6"	G1"–G6" R1"–R6" 1-11½–6-8NPT	24–90 mm 0.94–3.5"	140 kg

Chaser holders see table for holders

Accessories:

Setting device with dial gauge



Accessories:

Control ring WJK-WKK

