

Thread cutting system Z16-2

Standard rotating design

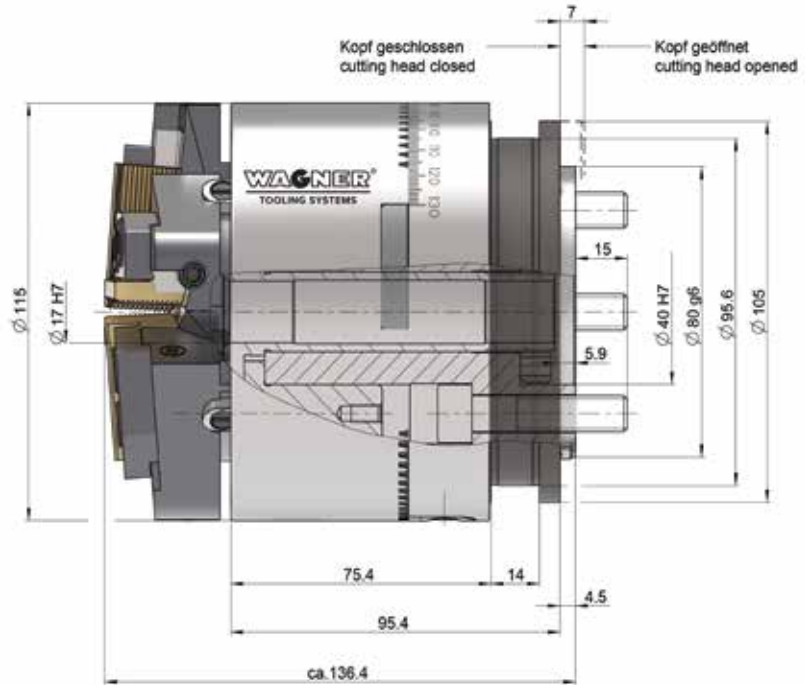
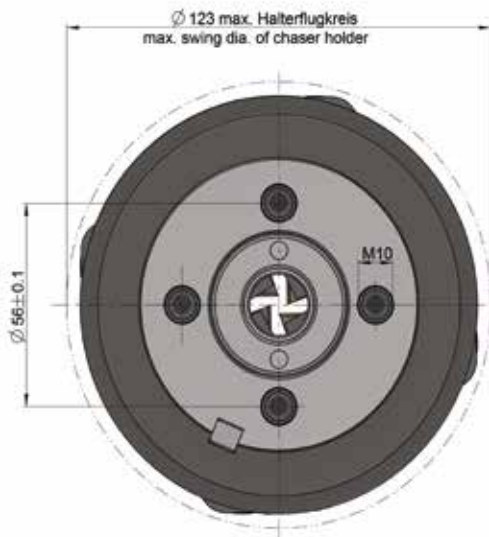

Thread cutting system Standard Z16-2

Weight 10 kg

	mm	inch
Working range \varnothing	4–45	0.157–1.77
Max. pitch	2.0	13 t.p.i.
Chaser holder	see table for holders	

Accessories:

Control ring Z16-2-70563700

Accessories:

Toothed segments Z16-2 (set = 10 pieces)

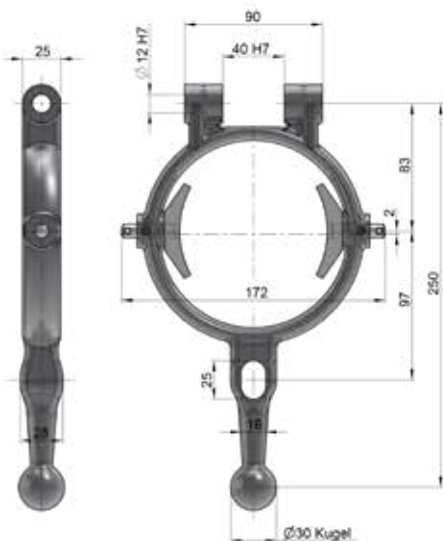

Toothed segments ensure an interlocking connection between the guide ring and the eccentric ring, thus preventing unintentional adjustment of the machining diameter.

Toothed segments are mainly used when the cutting systems are used in a reversing manner or the tool spindles are stopped abruptly after thread cutting.

Accessories:

Setting device with dial gauge



Accessories:

Shanks and flanges on request

