

Thread cutting system Z27-GK-2

Design for
tapered threads

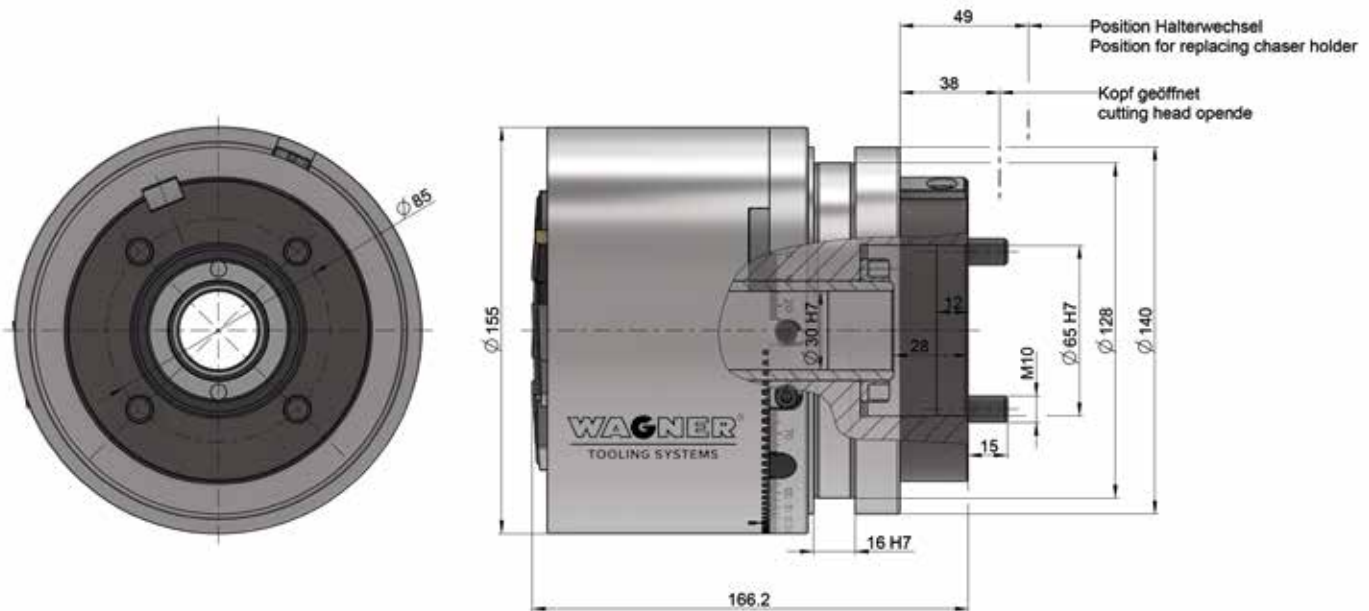

Thread cutting system for tapered threads Z27-GK-2

Weight 15 kg

	mm	inch
Working range nominal \varnothing	8–45	0.315–1.77
Max. pitch	2.5	10 t.p.i.
Tapered thread length	32	126
Eccentric rings and chaser holders	see table for holders	

Accessories:

Toothed segments Z27-GK (set = 10 pieces)



Toothed segments ensure an interlocking connection between the guide ring and the eccentric ring, thus preventing unintentional adjustment of the machining diameter.

Toothed segments are mainly used when the cutting systems are used in a reversing manner or the tool spindles are stopped abruptly after thread cutting.

Accessories:

Setting device with dial gauge

