

## Thread cutting system Z52-2

Standard rotating design

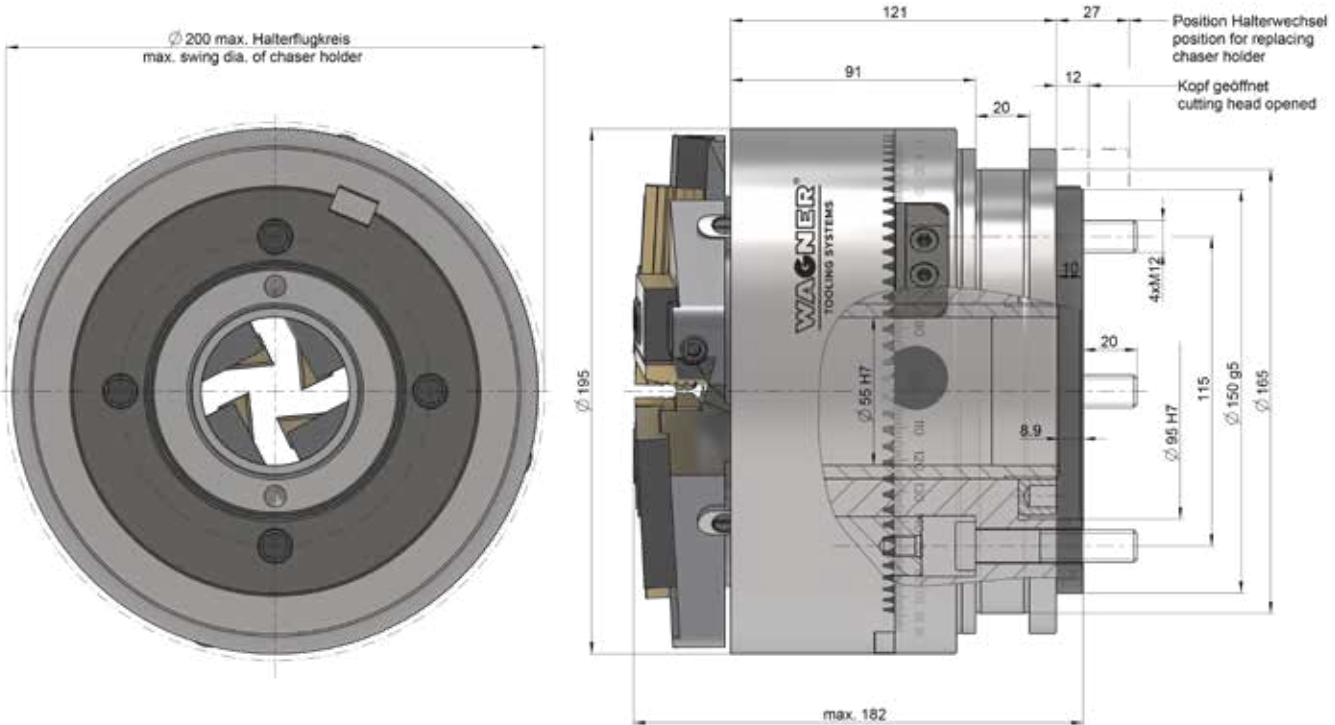

### Thread cutting system Standard Z52-2

Weight 31 kg

	mm	inch
Working range $\varnothing$	8–100	0.315–4
Max. pitch	5.5	4.5 t.p.i.
Chaser holder	see table for holders	

### Accessories:

Control ring Z52-2/Z64-2

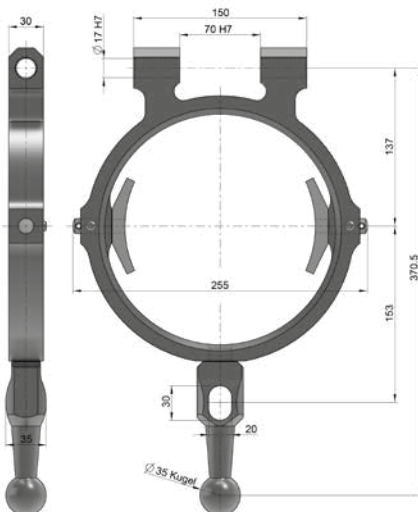

### Accessories:

Toothed segments Z52-2 (set = 10 pieces)



Toothed segments ensure an interlocking connection between the guide ring and the eccentric ring, thus preventing unintentional adjustment of the machining diameter.

Toothed segments are mainly used when the cutting systems are used in a reversing manner or the tool spindles are stopped abruptly after thread cutting.

### Accessories:

Setting device with dial gauge



### Accessories:

Shanks and flanges on request

