

Thread cutting system Z76-2

Standard rotating design

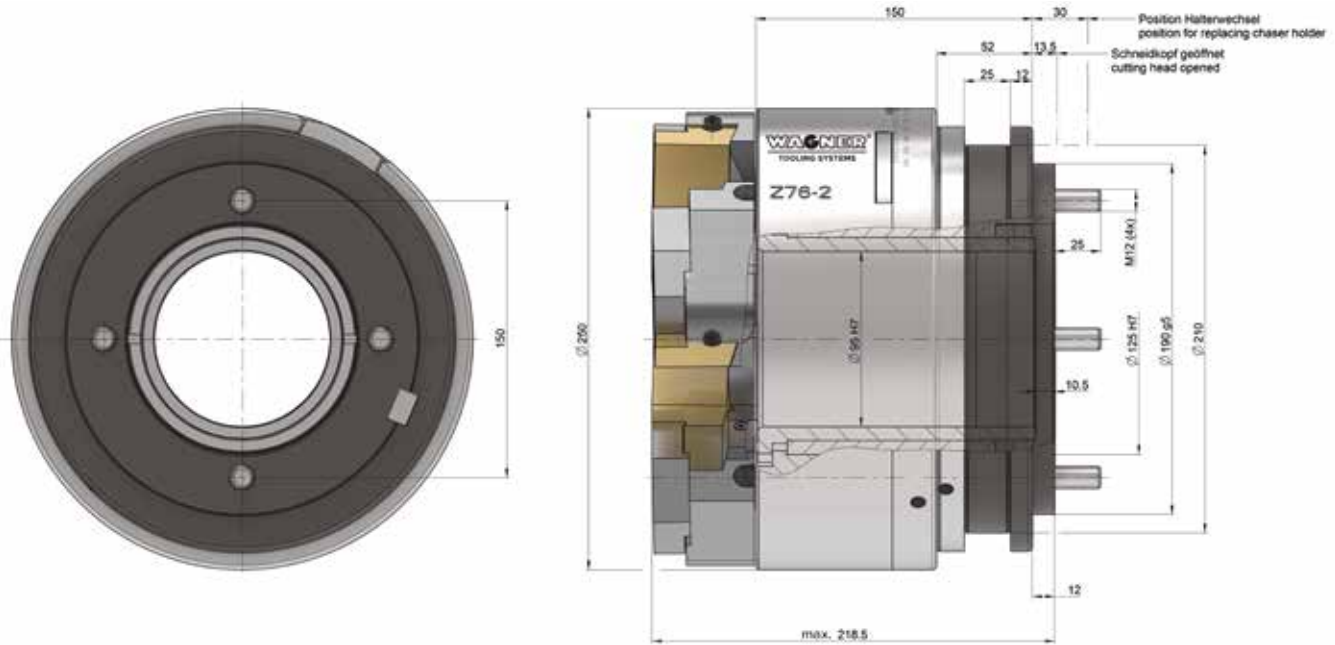

Thread cutting system Standard Z76-2

| | | |
|-----------------------------|-----------------------|---------------|
| Weight | 50 kg | |
| | mm | inch |
| Max. pitch | 3.125 | 8 t.p.i. |
| Working range \varnothing | R1–4" | 1-11.5–4-8NPT |
| Chaser holder | see table for holders | |

Accessories:

Setting device with dial gauge



Accessories:

Toothed segments Z76-2 (set = 10 pieces)



Toothed segments ensure an interlocking connection between the guide ring and the eccentric ring, thus preventing unintentional adjustment of the machining diameter.

Toothed segments are mainly used when the cutting systems are used in a reversing manner or the tool spindles are stopped abruptly after thread cutting.

Accessories:

Shanks and flanges on request

