

Thread cutting system ZA12

Compact stationary design

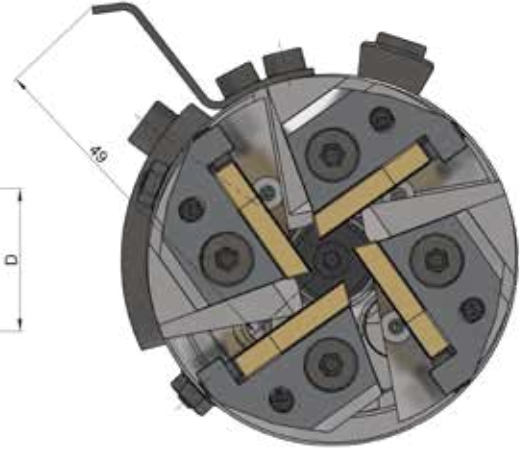
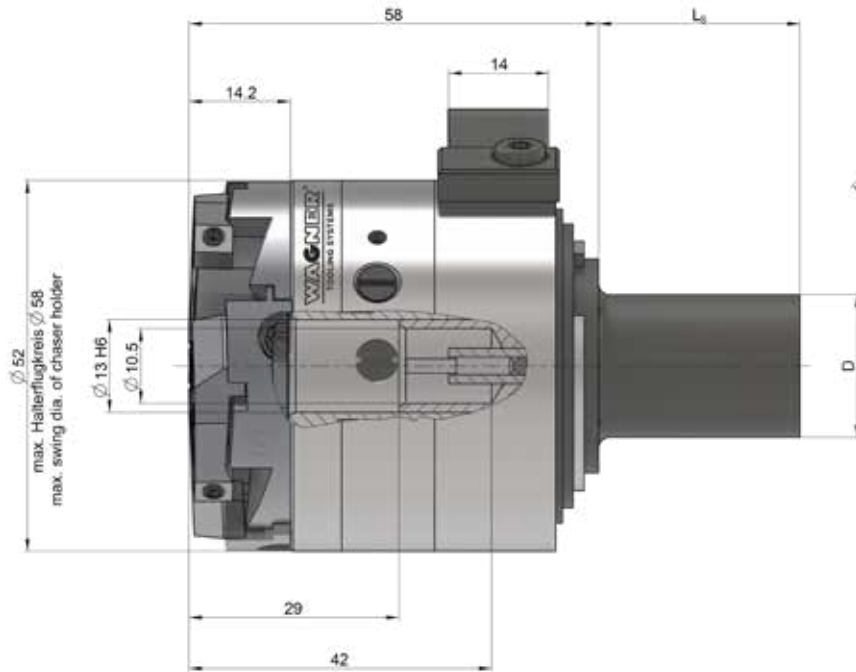

Thread cutting system compact ZA12

Weight 0,8 kg

	mm	inch
Working range \varnothing	1.6–16	0.063–0.591
Max. pitch	1.75	16 t.p.i.
Chaser holder	see holder tables	

Accessories:

Setting device with dial gauge



Fixed shanks ZA12

Shank- \varnothing D mm (inch)	Length L _s mm	Internal stop
12	30	yes
15.875 (5/8")	30	yes
16	30	yes
19.05 (3/4")	37	yes
20	30	yes

Feed compensation shanks ZA12

Shank- \varnothing D mm (inch)	Length L _s mm	Internal stop
15.875 (5/8")	32	yes
19.05 (3/4")	37	yes
20	37	yes