

## Thread cutting system ZA16

Compact stationary design

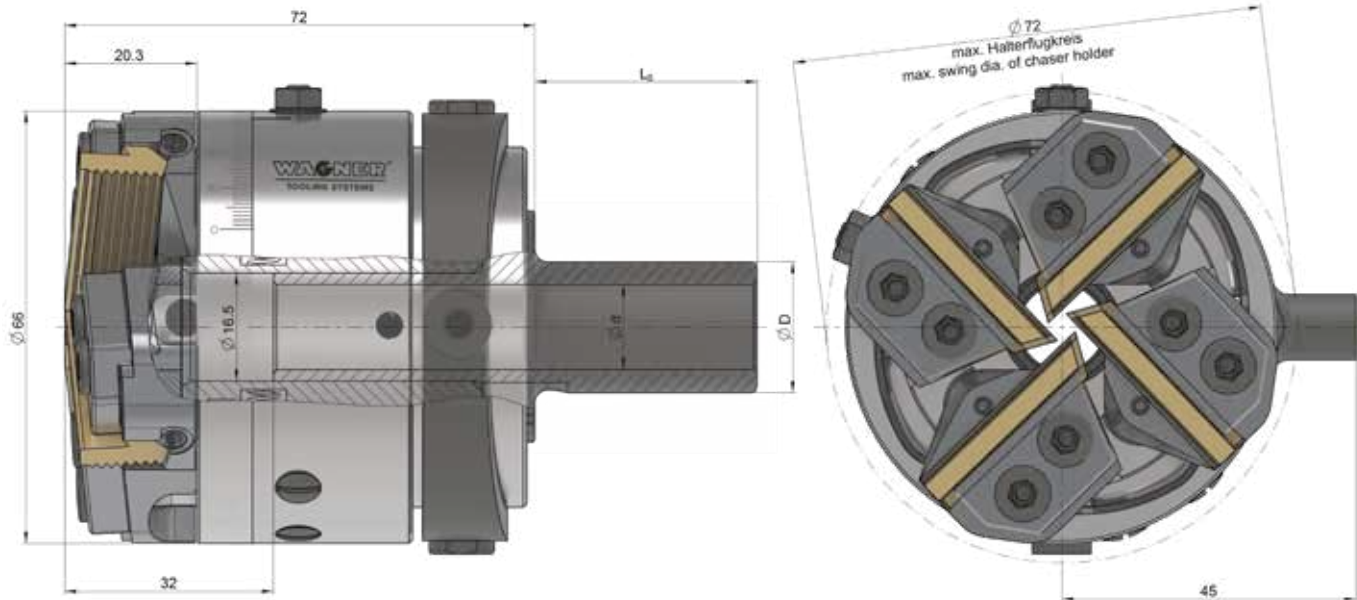

### Thread cutting system compact ZA16

Weight 1.7 kg

	mm	inch
Working range $\varnothing$	2.5–24	0.098–0.787
Max. pitch	2	13 t.p.i.
Chaser holder	see holder tables	

### Accessories:

Setting device with dial gauge



### Fixed shanks ZA16

Shank- $\varnothing$ D mm (inch)	Length $L_s$ mm	d mm	Internal stop	Max. thread length mm
15.875 (5/8")	30	6.4	–	up to $\varnothing$ 6: unlimited
16	34	–	yes	up to $\varnothing$ 10: 51
19.05 (3/4")	34	–	yes	up to $\varnothing$ 10: 51
19.05 (3/4")	42	13	–	up to $\varnothing$ 13: unlimited
20	34	–	yes	up to $\varnothing$ 10: 51
20	34	13	–	up to $\varnothing$ 13: unlimited
20	50	–	yes	up to $\varnothing$ 10: 51
22	42	14.2	–	up to $\varnothing$ 14: unlimited
25	72	10.5	–	up to $\varnothing$ 10: 51
25	42	–	yes	up to $\varnothing$ 10: 51
25	42	13	–	up to $\varnothing$ 13: unlimited
25.4 (1")	50	12	yes	up to $\varnothing$ 12: 51
25.4 (1")	50	12	–	up to $\varnothing$ 12: unlimited