

## Thread cutting system ZA22

Compact stationary design

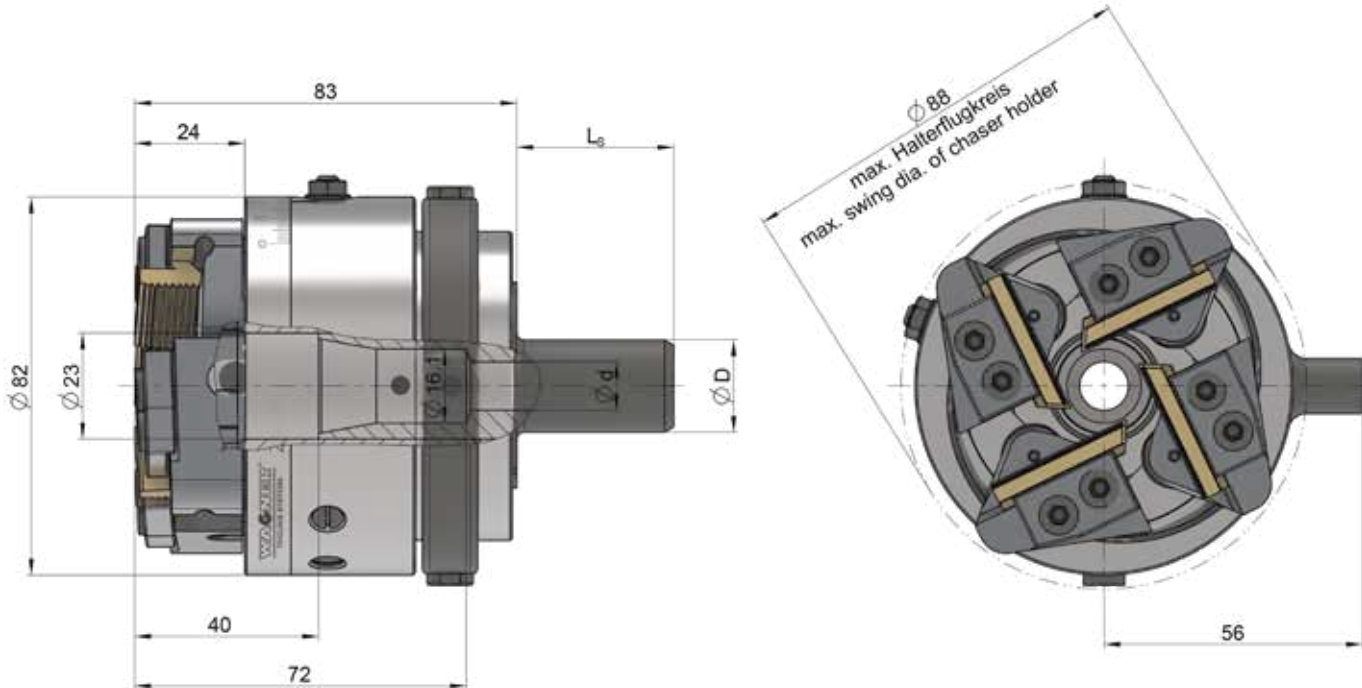

### Thread cutting system compact ZA22

Weight 2.8 kg

### Accessories:

Setting device with dial gauge

	mm	inch
Working range $\varnothing$	4–38	0.157–1.496
Max. pitch	2.5	10 t.p.i.
Chaser holder	see holder tables	

### Fixed shanks ZA22

Shank- $\varnothing$ D mm (inch)	Length $L_s$ mm	d mm	Internal stop	Max. thread length mm
16	42	10	yes	up to $\varnothing$ 16: 72
19.05 (3/4")	42	10	yes	up to $\varnothing$ 16: 72
20	50	10	yes	up to $\varnothing$ 16: 72
20	50	13	–	up to $\varnothing$ 13: unlimited
25	50	16	yes	up to $\varnothing$ 16: unlimited
25.4 (1")	50	16	yes	up to $\varnothing$ 16: unlimited
25.4 (1")	70	16	yes	up to $\varnothing$ 16: unlimited
30	50	16	yes	up to $\varnothing$ 16: unlimited
32	80	16	–	up to $\varnothing$ 16: unlimited
VDI20	40	16	–	up to $\varnothing$ 16: 71
VDI30	55	16	–	up to $\varnothing$ 16: 71
VDI40	63	16	–	up to $\varnothing$ 16: 71

