

Thread cutting system ZA27

Compact stationary design

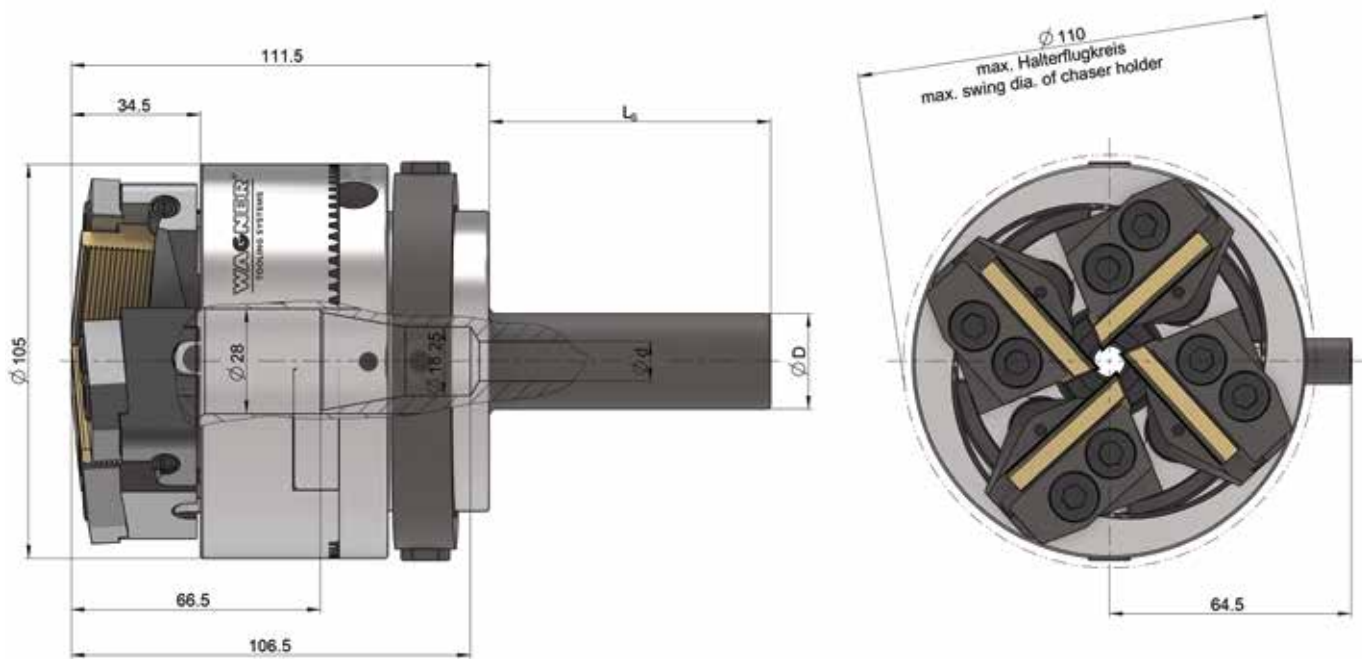

Thread cutting system compact ZA27

Weight 6.8 kg

	mm	inch
Working range \varnothing	5–60	0.197–2.362
Max. pitch	3	9 t.p.i.
Chaser holder	see holder tables	

Accessories:

Setting device with dial gauge



Fixed shanks ZA27

Shank- \varnothing D mm (inch)	Length L_s mm	d mm	Internal stop	Max. thread length mm
25.4 (1")	75	10.5	yes	up to \varnothing 10,5: unlimited
30	75	18	yes	up to \varnothing 18: unlimited
30	75	22.5	–	up to \varnothing 22,5: unlimited
31.75 (1¼")	75	18	yes	up to \varnothing 18: unlimited
38.1 (1½")	75	18	yes	up to \varnothing 18: unlimited
32	75	18	yes	up to \varnothing 18: unlimited
32	75	25	–	up to \varnothing 25: unlimited
34	75	22.5	–	up to \varnothing 22,5: unlimited
VDI30	70	18.5	–	up to \varnothing 18: 103.5
VDI40	78	18	–	up to \varnothing 18: 91.5